

BAFFLE DETAIL

NOTE:

- 1 - TANK USAGE: GREASE INTERCEPTOR.
- 2 - INVERT DIMENSIONS FROM TANK I.D.
- 3 - UPC LABEL IS LAMINATED ONTO INLET SIDE OF TANK.
- 4 - OPTIONAL PREFABRICATED DEADMEN SHOWN. IF DEADMEN ARE ADDED TO THE ORDER, ACCOMMODATIONS MAY BE REQUIRED TO SECURE THE STRAPS TO THE DEADMEN.

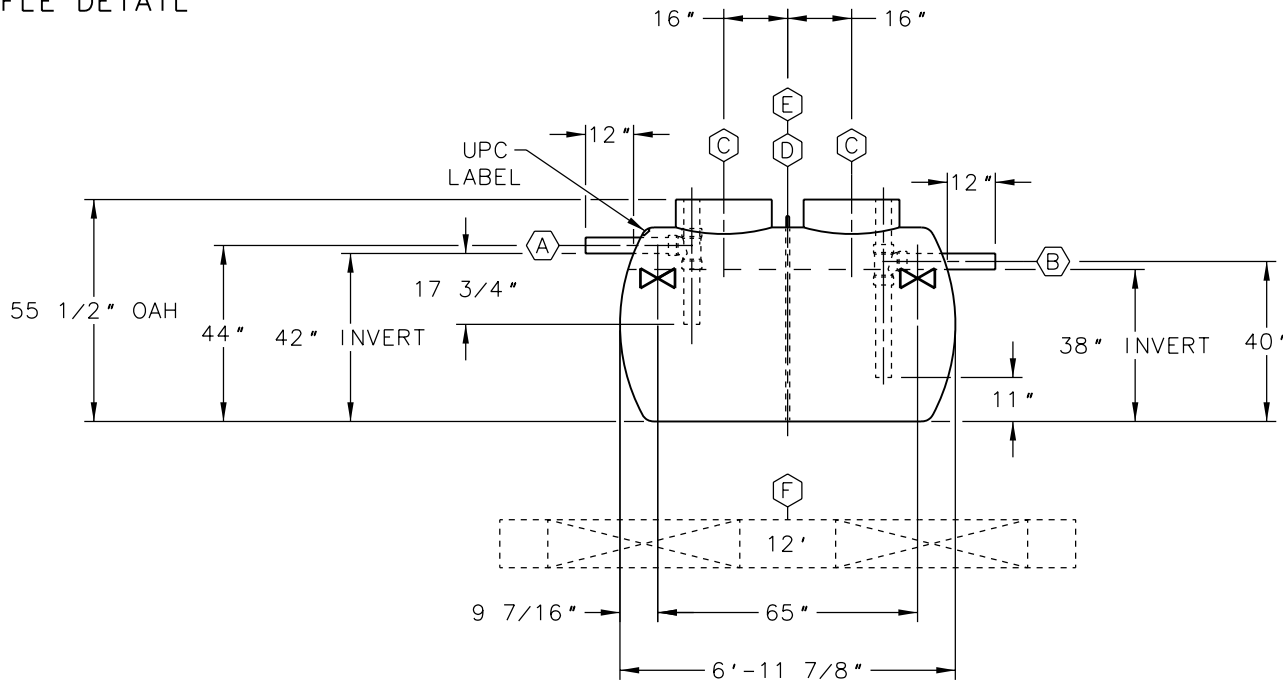

ITEM	QTY	DESCRIPTION
(A)	1	4"DIA SCH 40 PVC INLET PIPE WITH INTERNAL SANITARY TEE & PIPES
(B)	1	4"DIA SCH 40 PVC OUTLET PIPE WITH INTERNAL SANITARY TEE & PIPES
(C)	2	RISER PIPE, FOR 24"(NOMINAL) ACCESS OPENING
(D)	1	FULL PLATE BAFFLE WITH 3 - 4"DIA HOLES & 1 - 4"DIA VENT HOLE
(E)	1	LIFTING LUG
(F)	2	12' PREFABRICATED CONCRETE DEADMAN (OPTIONAL)
☒	2	HOLD DOWN STRAP LOCATION

RATED CAPACITY - 517 GALLONS

**XERXES**<sup>®</sup>  
a zcl company

TITLE 4' DIA SINGLE-WALL  
CAP. 600 GALLONS  
IAPMO - ANSI Z1001

DATE 1-12 DR. NO. S11-639.00